

Assembly Overview:

Gutter LT Installation Guide

This guide is provided to assist you in the installation process. Additional assistance is available by calling us at 888-321-9630. Thank you for choosing Drexel Metals.

Contents:

Assembly Overview	1
Step 1: Installing Outlet Tubes	2
Step 2: Installing End Caps	2
Step 3: Installing Miters	2
Step 4: Installing Expansion Joints	2
Step 5: Installing Straight Lengths	3
Step 6: Installing Joint Splices	3
Step 7: Installing Brackets	3
Detail: Gutter LT	4

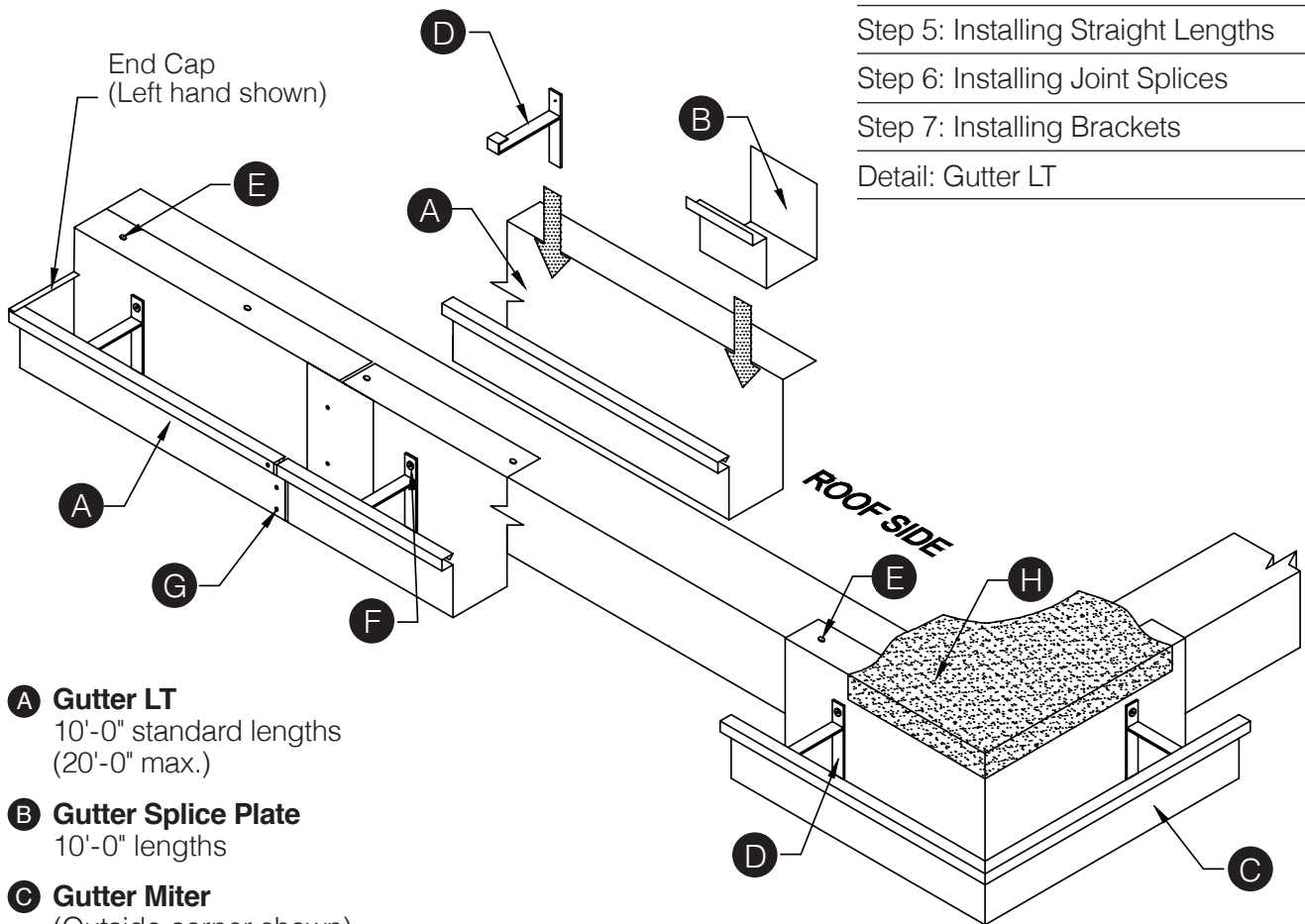

- A Gutter LT**
10'-0" standard lengths
(20'-0" max.)
- B Gutter Splice Plate**
10'-0" lengths
- C Gutter Miter**
(Outside corner shown)
- D Gutter Bracket**
(24" o.c. max.)
- E #10-13x1" S.S. Panhead Woodscrew**
at 12" o.c. (Included and required)
- F #9-13x1-1/2" S.S. Washered Screw**
One (1) per bracket (Included and required)
- G Pop Rivet**
- H Approved Roofing Membrane**
(By installer)

Step 1: Installing Downspout Outlet Tubes

- Determine outlet locations and field cut hole in the gutter bottom.
- Insert Outlet Tube in hole, apply a continuous bead of urethane Tube Sealant to the flange, and fasten with two (2) Pop Rivets in each flange from outside the Gutter bottom.

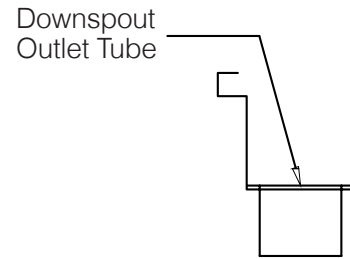

Step 2: Installing Gutter End Caps

- Locate the End Caps for the appropriate Gutter End.
- Place the End Cap into position and secure to Gutter with Pop Rivets.
- Apply a continuous bead of urethane Tube Sealant around the inside flange of the End Cap.

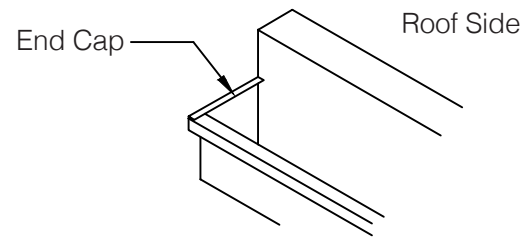

Step 3: Installing Gutter Miters

- Locate the Miters for the appropriate locations.
- Secure the Miter to the roof edge using #10-13x1" S.S. Panhead Woodscrews provided, at every pre-punched hole or 12" o.c. maximum.

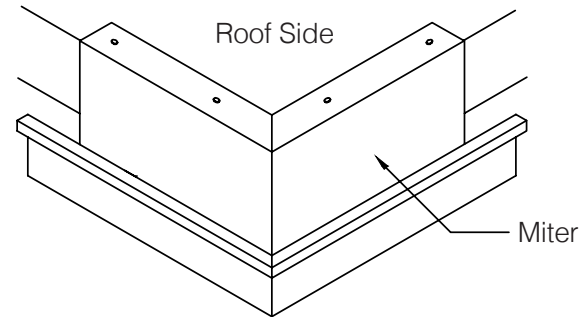

Step 4: Installing Expansion Joints (If required)

- Install expansion joint in location as specified on roof plans.
- An expansion joint will consist of two (2) pre-fabricated End Caps, one (1) Joint Plate, and one (1) Joint Cover.
- Gap the End Caps at 1" maximum.
- Slide the Joint Plate onto the Gutter, then secure with Pop Rivets to one of the Gutter Ends.
- Place the Joint Cover over the End Cap lips and secure with Pop Rivets to only one of the Gutter Ends.

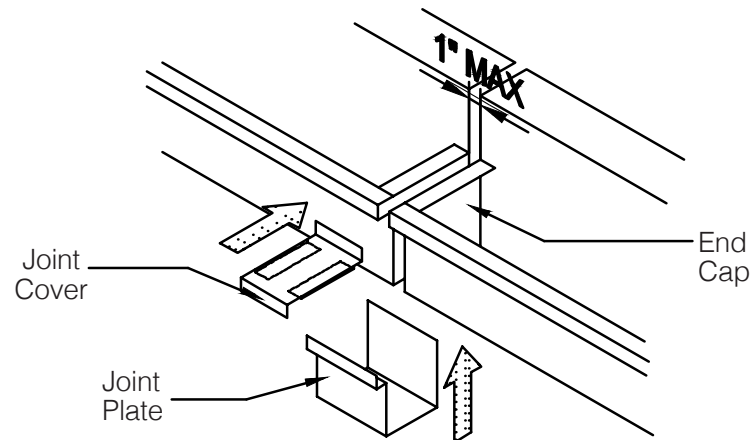

Step 5: Installing Gutter Straight Lengths

- Begin from the End Caps/Miters working inward to the center.
- Allow 1/4" gap between Gutter sections for thermal expansion.
- Secure Gutter to roof with #10-13x1" S.S. Panhead Screws provided, at 12" on center in each pre-punched hole.

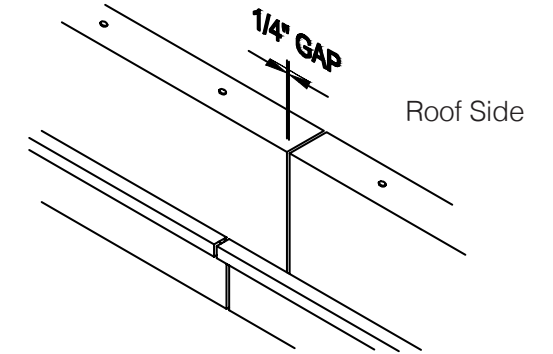

Step 6: Installing Gutter Joint Splices

- Locate the joint splice and apply a continuous bead of urethane Tube Sealant to both sides of the joint inside the gutter.
- Slide the Splice Plate down into the Gutter and secure with Pop Rivets on the up slope side of the splice, as shown in figure #1 and #2.

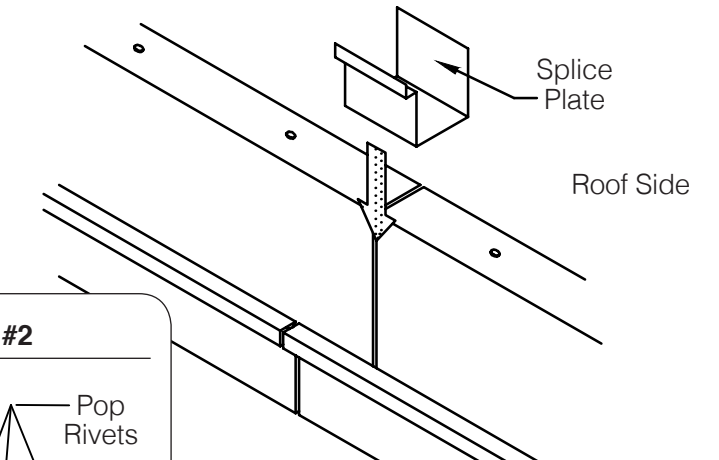

Figure #1

Water Flow

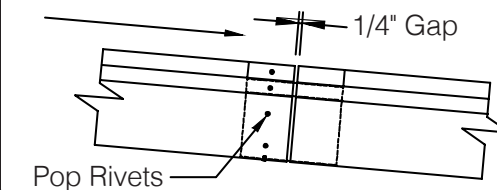
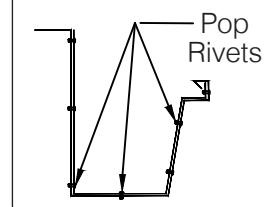
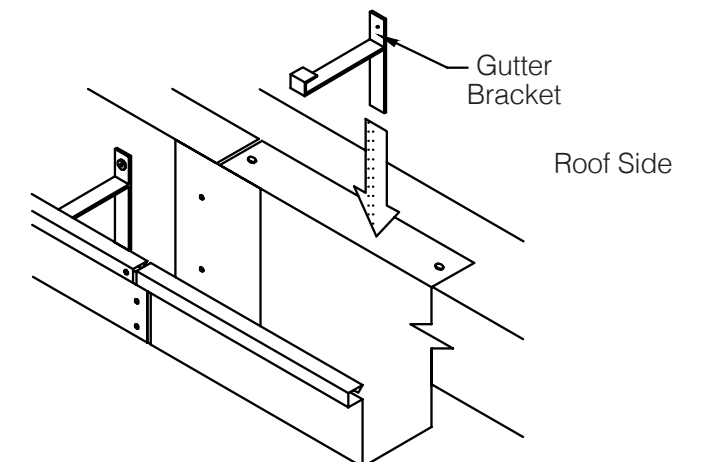

Figure #2



Step 7: Installing Gutter Brackets

- Hook the top part of the Gutter Bracket into the face lip of the Gutter.
- Rotate the bracket down into the Gutter and secure the bracket through the Gutter, into the treated wood nailer, with one (1) #9-13x1-1/2" S.S. Woodscrew.
- Install brackets at 24" on center maximum.
- Install roof membrane into Gutter per roof manufacturer's instructions.



Gutter LT

Detail: Gutter LT – performance series

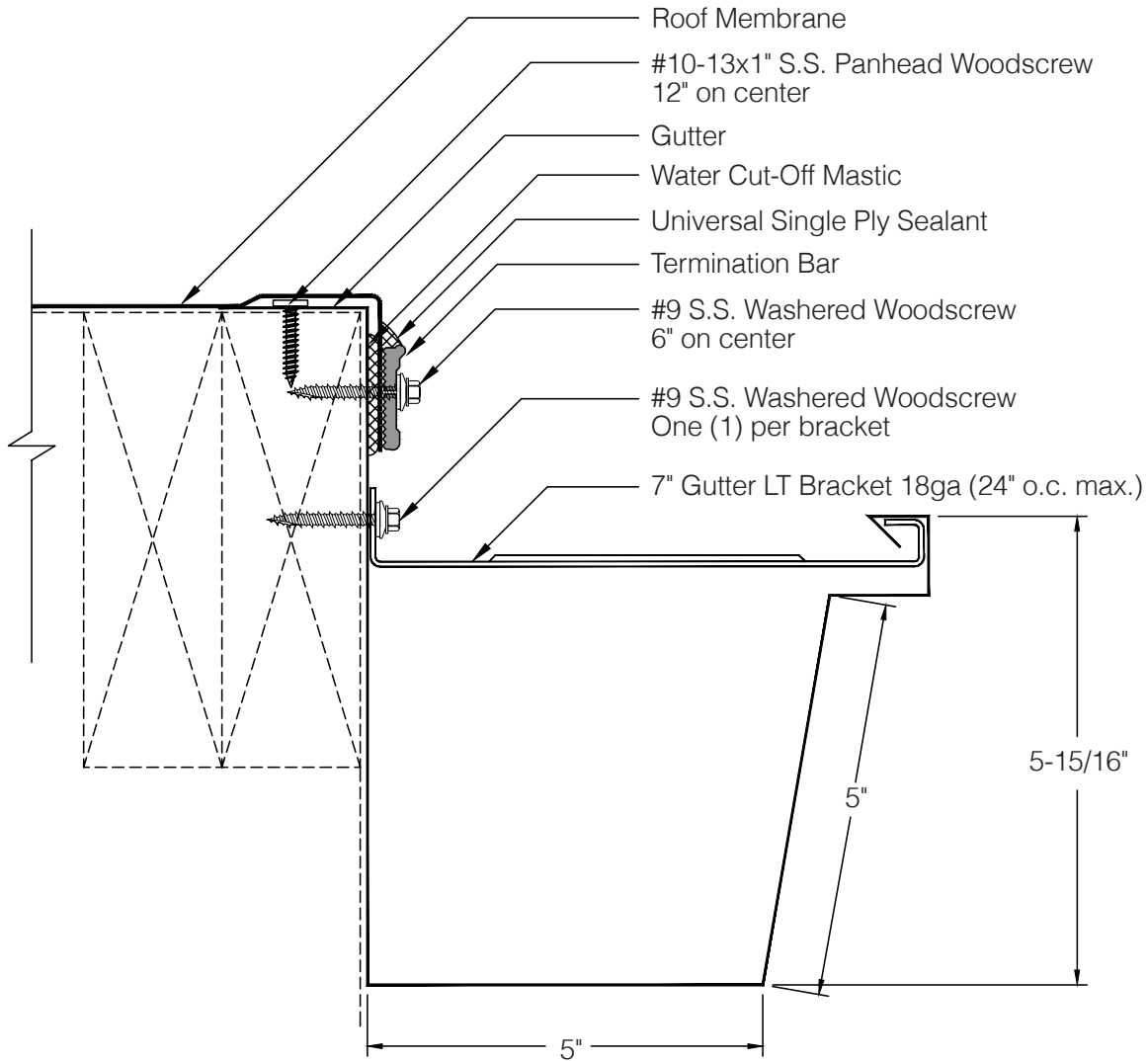

Notes:

1. Isolate all metal parts from ACQ treated wood or other galvanically incompatible material with appropriate membrane material.
2. Appliance attachments, such as lightning rods, signs, or antennae that penetrate the water seal, induce a galvanic reaction, or otherwise compromise the effectiveness of the roof edge system, shall be eliminated or isolated to prevent problems per section 8.0 if ANSI/SPRI ES-1. Appliances should also be isolated from, or not attached to, the roof edge system. Consult the lightning protection system manufacturer for specific attachment instructions.

REELFOOT METAL ROOFING SYSTEMS
342 Bellvue St, Jackson, TN 38301
888-265-4330 Fax 731-265-4309

www.reelfootmetal.com

